



INVOIC Invoice message

EDIFACT/D97A/INVOIC: INVOIC Invoice message

Version: 1.0 Final

Author:	Ingram Micro
Company:	
Created:	23/02/2021
Modified:	09/03/2021
Current:	09/03/2021

Table of Contents

INVOIC	Invoice message.....	1
	Branching Diagram - 1	3
	Branching Diagram - 2	4
	Branching Diagram - 3	5
	Branching Diagram - 4	6
UNB	INTERCHANGE HEADER	7
UNH	Message header	9
BGM	Beginning of message	10
DTM	DATE/TIME/PERIOD.....	11
Group 1	Segment Group 1.....	12
RFF	REFERENCE	13
Group 2	Segment Group 2.....	14
NAD	Name and address	15
Group 3	Segment Group 3.....	17
RFF	REFERENCE	18
Group 5	Segment Group 5.....	19
CTA	Contact information.....	20
COM	Communication contact	21
Group 7	Segment Group 7.....	22
CUX	Currencies	23
Group 8	Segment Group 8.....	25
PAT	Payment terms basis	26
DTM	Payment Due Date	27
Group 25	Segment Group 25	28
LIN	Line item	29
PIA	Additional product id	30
IMD	Item description	31
QTY	Quantity	32
GIN	Goods identity number.....	33
Group 26	Segment Group 26	34
MOA	Monetary amount.....	35
Group 28	Segment Group 28	36
PRI	Price details	37
Group 29	Segment Group 29	38
RFF	Customer Purchase Order code	39
Group 33	Segment Group 33	40
TAX	Duty/tax/fee details.....	41
MOA	Monetary amount.....	42
Group 38	Segment Group 38	43
ALC	Allowance or charge.....	44
Group 41	Segment Group 41	45
MOA	Monetary amount.....	46
Group 43	Segment Group 43	47
TAX	Duty/tax/fee details.....	48
UNS	Section control	49
CNT	Control total	50
Group 49	Segment Group 49	51
MOA	Monetary amount.....	52
Group 51	Segment Group 51	54
TAX	Duty/tax/fee details.....	55
MOA	Monetary amount.....	56
Group 52	Segment Group 52	57
ALC	Allowance or charge.....	58
MOA	Monetary amount.....	59
UNT	Message trailer	60
UNZ	INTERCHANGE TRAILER	61

INVOIC

Invoice message

Message Status=

Not Defined:

Pos	Tag	Segment Name	Status	Rep	Notes	Usage
	UNB	INTERCHANGE HEADER	M	1		Must use

Heading:

Pos	Tag	Segment Name	Status	Rep	Notes	Usage
0010	UNH	Message header	M	1	N1/0010	Must use
0020	BGM	Beginning of message	M	1	N1/0020	Must use
0030	DTM	DATE/TIME/PERIOD	M	35	N1/0030	Must use
0110		Segment Group 1	C	99	N1/0110	Used
0120	RFF	REFERENCE	M	1	N1/0120	Must use
0200		Segment Group 2	C	99	N1/0200	Used
0210	NAD	Name and address	M	1	N1/0210	Must use
0240		Segment Group 3	C	9999	N1/0240	Used
0250	RFF	REFERENCE	M	1	N1/0250	Must use
0300		Segment Group 5	C	5	N1/0300	Used
0310	CTA	Contact information	M	1	N1/0310	Must use
0320	COM	Communication contact	C	5	N1/0320	Used
0370		Segment Group 7	C	5	N1/0370	Used
0380	CUX	Currencies	M	1	N1/0380	Must use
0400		Segment Group 8	C	10	N1/0400	Used
0410	PAT	Payment terms basis	M	1	N1/0410	Must use
0420	DTM	Payment Due Date	C	5	N1/0420	Used

Detail:

Pos	Tag	Segment Name	Status	Rep	Notes	Usage
1030		Segment Group 25	C	9999999	N2/1030	Used
1040	LIN	Line item	M	1	N2/1040	Must use
1050	PIA	Additional product id	C	25	N2/1050	Used
1060	IMD	Item description	C	10	N2/1060	Used
1080	QTY	Quantity	C	5	N2/1080	Used
1120	GIN	Goods identity number	C	1000	N2/1120	Used
1180		Segment Group 26	C	10	N2/1180	Used
1190	MOA	Monetary amount	M	1	N2/1190	Must use
1260		Segment Group 28	C	25	N2/1260	Used
1270	PRI	Price details	M	1	N2/1270	Must use
1320		Segment Group 29	C	10	N2/1320	Used
1330	RFF	Customer Purchase Order code	M	1	N2/1330	Must use
1480		Segment Group 33	C	99	N2/1480	Used
1490	TAX	Duty/tax/fee details	M	1	N2/1490	Must use
1500	MOA	Monetary amount	C	1	N2/1500	Used
1640		Segment Group 38	C	30	N2/1640	Used
1650	ALC	Allowance or charge	M	1	N2/1650	Must use
1750		Segment Group 41	C	2	N2/1750	Used
1760	MOA	Monetary amount	M	1	N2/1760	Must use

<u>1830</u>		<u>Segment Group 43</u>	<u>C</u>	<u>5</u>	<u>N2/1830</u>	<u>Used</u>
1840	TAX	Duty/tax/fee details	M	1	N2/1840	Must use
2090	UNS	Section control	M	1	N2/2090	Must use
2100	CNT	Control total	C	10	N2/2100	Used
<u>2110</u>		<u>Segment Group 49</u>	<u>M</u>	<u>100</u>	<u>N2/2110</u>	<u>Must use</u>
2120	MOA	Monetary amount	M	1	N2/2120	Must use
<u>2160</u>		<u>Segment Group 51</u>	<u>C</u>	<u>10</u>	<u>N2/2160</u>	<u>Used</u>
2170	TAX	Duty/tax/fee details	M	1	N2/2170	Must use
2180	MOA	Monetary amount	C	2	N2/2180	Used
<u>2190</u>		<u>Segment Group 52</u>	<u>C</u>	<u>15</u>	<u>N2/2190</u>	<u>Used</u>
2200	ALC	Allowance or charge	M	1	N2/2200	Must use
2220	MOA	Monetary amount	C	2	N2/2220	Used
2240	UNT	Message trailer	M	1	N2/2240	Must use

Not Defined:

<u>Pos</u>	<u>Tag</u>	<u>Segment Name</u>	<u>Status</u>	<u>Rep</u>	<u>Notes</u>	<u>Usage</u>
	UNZ	INTERCHANGE TRAILER	M	1		Must use

Branching Diagram: INVOIC(Invoice message)

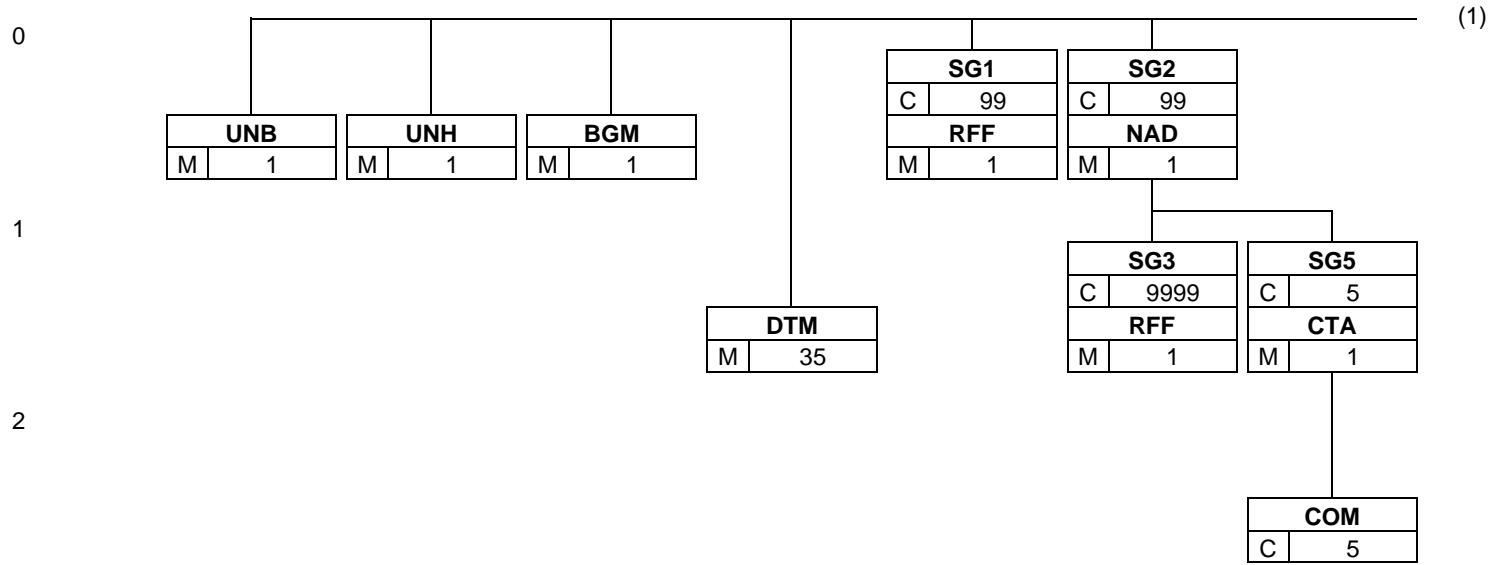

Branching Diagram: INVOIC(Invoice message)

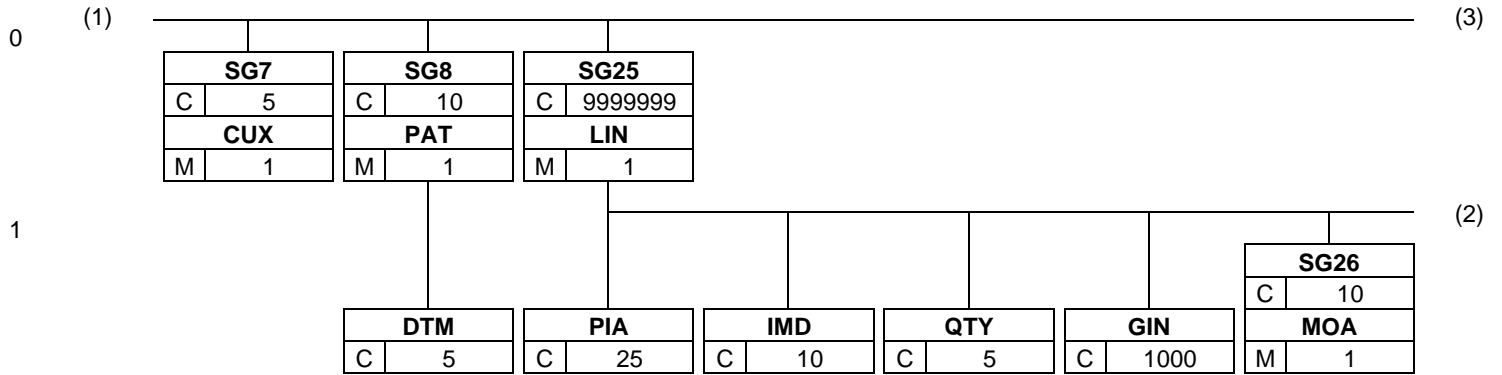

Branching Diagram: INVOIC(Invoice message)

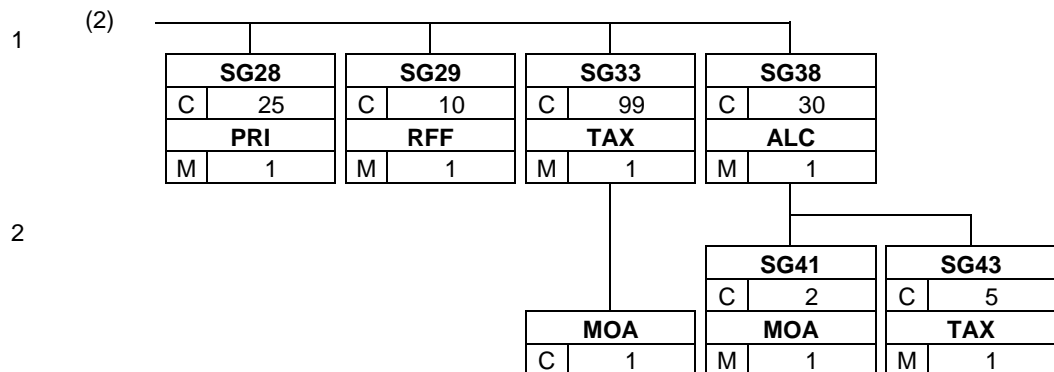

Branching Diagram: INVOIC(Invoice message)

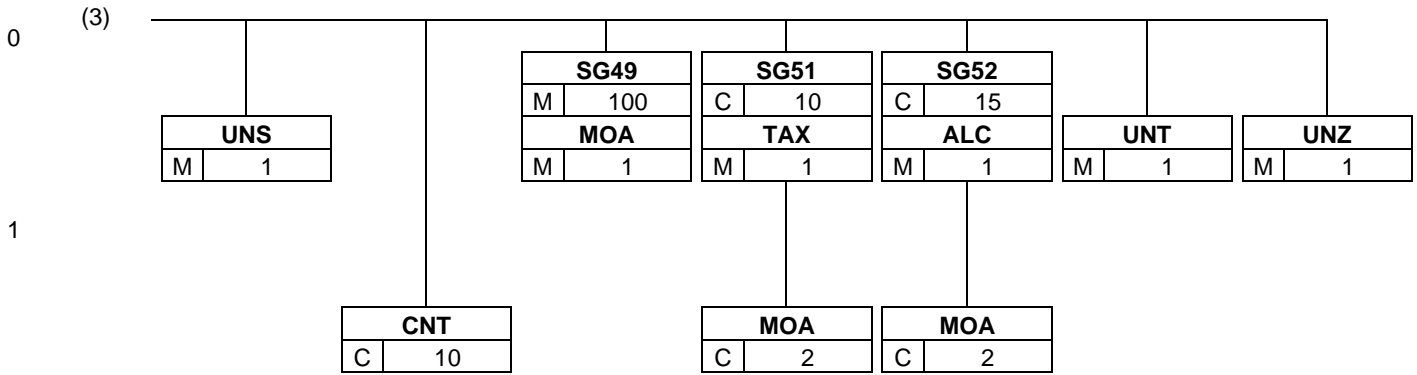

UNB INTERCHANGE HEADER

Pos:	Max: 1
Mandatory	
Group: N/A	Elements: 7

User Option (Usage): Must use

Function: To start, identify and specify an interchange.

Element Summary:

<u>Ref</u>	<u>Tag</u>	<u>Element Name</u>	<u>Status</u>	<u>Type</u>	<u>Min/Max</u>	<u>Usage</u>
UNB010	S001	SYNTAX IDENTIFIER	M	Comp		Must use
		Description: Identification of the agency controlling the syntax and indication of syntax level.				
UNB010-010	0001	Syntax identifier	M	a	4/4	Must use
		Description: Coded identification of the agency controlling a syntax and syntax level used in an interchange.				
		CodeList Summary (Total Codes: 6, Included: 1)				
		<u>Code</u>		<u>Name</u>		
		UNOC		UN/ECE level C		
				Description: <i>As defined in ISO 8859-1 : Information processing - Part 1: Latin alphabet No. 1.</i>		
UNB010-020	0002	Syntax version number	M	n	1/1	Must use
		Description: Version number of the syntax identified in the syntax identifier (0001).				
		CodeList Summary (Total Codes: 3, Included: 1)				
		<u>Code</u>		<u>Name</u>		
		2		Version 2		
				Description: <i>ISO 9735:1990.</i>		
UNB020	S002	INTERCHANGE SENDER	M	Comp		Must use
		Description: Identification of the sender of the interchange.				
UNB020-010	0004	Sender identification	M	an	1/35	Must use
		Description: Name or coded representation of the sender of a data interchange.				
UNB020-020	0007	Partner identification code qualifier	C	an	1/4	Used
		Description: Qualifier referring to the source of codes for the identifiers of interchanging partners.				
UNB030	S003	INTERCHANGE RECIPIENT	M	Comp		Must use
		Description: Identification of the recipient of the interchange.				
UNB030-010	0010	Recipient identification	M	an	1/35	Must use
		Description: Name or coded representation of the recipient of a data interchange.				
UNB030-020	0007	Partner identification code qualifier	C	an	1/4	Used
		Description: Qualifier referring to the source of codes for the identifiers of interchanging partners.				
UNB040	S004	DATE/TIME OF PREPARATION	M	Comp		Must use

		Description: Date/time of preparation of the interchange.				
UNB040-010	0017	Date of preparation	M	n	6/6	Must use
		Description: Local date when an interchange or a functional group was prepared.				
UNB040-020	0019	Time of preparation	M	n	4/4	Must use
		Description: Local time of day when an interchange or a functional group was prepared.				
UNB050	0020	Interchange control reference	M	an	1/14	Must use
		Description: Unique reference assigned by the sender to an interchange.				
UNB070	0026	Application reference	C	an	1/14	Used
		Description: Identification of the application area assigned by the sender, to which the messages in the interchange relate e.g. the message identifier if all the messages in the interchange are of the same type.				
UNB110	0035	Test indicator	C	n	1/1	Used
		Description: Indication that the interchange is a test.				

CodeList Summary (Total Codes: 1, Included: 1)

<u>Code</u>	<u>Name</u>
1	Interchange is a test Description: <i>Indicates that the interchange is a test.</i>

Example:

```
UNA:+.? '
UNB+UNOC:2+004919486DE:01+RESELLER:14+070808:0955+00000000000024++INVOIC++++1'
```

UNH

Message header

Pos: 0010	Max: 1
Mandatory	
Group: N/A	Elements: 2

User Option (Usage): Must use

Function: To head, identify and specify a message.

Element Summary:

<u>Ref</u>	<u>Tag</u>	<u>Element Name</u>	<u>Status</u>	<u>Type</u>	<u>Min/Max</u>	<u>Usage</u>				
UNH010	0062	Message reference number Description: Unique message reference assigned by the sender.	M	AN	1/14	Must use				
UNH020	S009	Message identifier Description: Identification of the type, version etc. of the message being interchanged.	M	Comp		Must use				
UNH020-010	0065	Message type identifier CodeList Summary (Total Codes: 145, Included: 1) <table border="1"> <thead> <tr> <th><u>Code</u></th> <th><u>Name</u></th> </tr> </thead> <tbody> <tr> <td>INVOIC</td> <td>Invoice message</td> </tr> </tbody> </table> Description: <i>Message claiming payment for goods and services.</i>	<u>Code</u>	<u>Name</u>	INVOIC	Invoice message	M	AN	1/6	Must use
<u>Code</u>	<u>Name</u>									
INVOIC	Invoice message									
UNH020-020	0052	Message type version number CodeList Summary (Total Codes: 7, Included: 1) <table border="1"> <thead> <tr> <th><u>Code</u></th> <th><u>Name</u></th> </tr> </thead> <tbody> <tr> <td>D</td> <td>Draft version</td> </tr> </tbody> </table> Description: <i>Message approved and issued as a draft message (Valid for directories published after March 1993 and prior to March 1997). Message approved as a standard message (Valid for directories published after March 1997).</i>	<u>Code</u>	<u>Name</u>	D	Draft version	M	AN	1/3	Must use
<u>Code</u>	<u>Name</u>									
D	Draft version									
UNH020-030	0054	Message type release number Description: Release number within the current message type version number (0052). CodeList Summary (Total Codes: 15, Included: 1) <table border="1"> <thead> <tr> <th><u>Code</u></th> <th><u>Name</u></th> </tr> </thead> <tbody> <tr> <td>97A</td> <td>Release 1997 - A</td> </tr> </tbody> </table> Description: <i>Message approved and issued in the first 1997 release of the UNTDID (United Nations Trade Data Interchange Directory).</i>	<u>Code</u>	<u>Name</u>	97A	Release 1997 - A	M	AN	1/3	Must use
<u>Code</u>	<u>Name</u>									
97A	Release 1997 - A									
UNH020-040	0051	Controlling agency Description: Code identifying the agency controlling the specification, maintenance and publication of the message type. CodeList Summary (Total Codes: 20, Included: 1) <table border="1"> <thead> <tr> <th><u>Code</u></th> <th><u>Name</u></th> </tr> </thead> <tbody> <tr> <td>UN</td> <td>UN/ECE/TRADE/WP.4, United Nations Standard Messages (UNSM)</td> </tr> </tbody> </table> Description: <i>UN Economic Commission for Europe (UN/ECE), Committee on the development of trade (TRADE), Working Party on facilitation of international trade procedures (WP.4).</i>	<u>Code</u>	<u>Name</u>	UN	UN/ECE/TRADE/WP.4, United Nations Standard Messages (UNSM)	M	AN	1/2	Must use
<u>Code</u>	<u>Name</u>									
UN	UN/ECE/TRADE/WP.4, United Nations Standard Messages (UNSM)									

Example:

UNH+00000000000001+INVOIC:D:97A:UN'

BGM Beginning of message

Pos: 0020	Max: 1
Mandatory	
Group: N/A	Elements: 3

User Option (Usage): Must use

Function: To indicate the type and function of a message and to transmit the identifying number.

Element Summary:

<u>Ref</u>	<u>Tag</u>	<u>Element Name</u>	<u>Status</u>	<u>Type</u>	<u>Min/Max</u>	<u>Usage</u>						
BGM010	C002	Document/message name Description: Identification of a type of document/message by code or name.	C	Comp		Used						
BGM010-010	1001	Document/message name, coded Description: Document/message identifier expressed in code. CodeList Summary (Total Codes: 424, Included: 2) <table border="1"> <thead> <tr> <th><u>Code</u></th> <th><u>Name</u></th> </tr> </thead> <tbody> <tr> <td>380</td> <td>Commercial invoice Description: <i>Document/message claiming payment for goods or services supplied under conditions agreed between seller and buyer.</i></td> </tr> <tr> <td>381</td> <td>Credit note Description: <i>Document/message for providing credit information to the relevant party.</i></td> </tr> </tbody> </table>	<u>Code</u>	<u>Name</u>	380	Commercial invoice Description: <i>Document/message claiming payment for goods or services supplied under conditions agreed between seller and buyer.</i>	381	Credit note Description: <i>Document/message for providing credit information to the relevant party.</i>	C	AN	1/3	Used
<u>Code</u>	<u>Name</u>											
380	Commercial invoice Description: <i>Document/message claiming payment for goods or services supplied under conditions agreed between seller and buyer.</i>											
381	Credit note Description: <i>Document/message for providing credit information to the relevant party.</i>											
BGM020	C106	Document/message identification Description: Identification of a document/message by its number and eventually its version or revision.	C	Comp		Used						
BGM020-010	1004	Document/message number Description: Reference number assigned to the document/message by the issuer. User Note: <i>Ingram Micro invoice / credit note number</i>	C	AN	1/35	Used						
BGM030	1225	Message function, coded Description: Code indicating the function of the message. CodeList Summary (Total Codes: 55, Included: 1) <table border="1"> <thead> <tr> <th><u>Code</u></th> <th><u>Name</u></th> </tr> </thead> <tbody> <tr> <td>9</td> <td>Original Description: <i>Initial transmission related to given transaction</i></td> </tr> </tbody> </table>	<u>Code</u>	<u>Name</u>	9	Original Description: <i>Initial transmission related to given transaction</i>	C	AN	1/3	Used		
<u>Code</u>	<u>Name</u>											
9	Original Description: <i>Initial transmission related to given transaction</i>											

Example:

BGM+380+440405253:9'

DTM DATE/TIME/PERIOD

Pos: 0030	Max: 35
Mandatory	
Group: N/A	Elements: 1

User Option (Usage): Must use

Element Summary:

<u>Ref</u>	<u>Tag</u>	<u>Element Name</u>	<u>Status</u>	<u>Type</u>	<u>Min/Max</u>	<u>Usage</u>
DTM010	C507	DATE/TIME/PERIOD	M	Comp		Must use
Description: Date relevant to the specified date type.						
DTM010-010	2005	Date/time/period qualifier	M	AN	1/3	Must use
Description: Code giving specific meaning to a date.						
CodeList Summary (Total Codes: 364, Included: 2)						
		<u>Code</u>		<u>Name</u>		
		3		Invoice date/time		
				Description: [2376] Date when a Commercial Invoice is issued.		
		137		Document/message date		
				Description: Date when a document/message is issued.		
DTM010-020	2380	Date/time/period	C	AN	1/35	Used
Description: The value of a date, a date and time, a time or of a period in a specified representation.						
DTM010-030	2379	Date/time/period format qualifier	C	AN	1/3	Used
Description: Specification of the representation of a date.						
CodeList Summary (Total Codes: 70, Included: 1)						
		<u>Code</u>		<u>Name</u>		
		102		CCYYMMDD		
				Description: Calendar date:		
				CC = Century, YY = Year, MM = Month, DD = Day.		

Example:

DTM+3:20070730:102'
DTM+137:20070809:102'

Segment Group 1

Pos: 0110	Repeat: 99
Conditional	
Group: 1	Elements: N/A

User Option (Usage): Used

Segment Group Summary:

<u>Pos</u>	<u>Tag</u>	<u>Segment Name</u>	<u>Status</u>	<u>Rep</u>	<u>Usage</u>
0120	RFF	REFERENCE	M	1	Must use

RFF

REFERENCE

Pos: 0120	Max: 1
Mandatory	
Group: 1	Elements: 1

User Option (Usage): Must use

Element Summary:

<u>Ref</u>	<u>Tag</u>	<u>Element Name</u>	<u>Status</u>	<u>Type</u>	<u>Min/Max</u>	<u>Usage</u>
RFF010	C506	Reference <i>Description:</i> Identification of a reference.	M	Comp		Must use
RFF010-010	1153	Reference qualifier <i>Description:</i> Code giving specific meaning to a reference segment or a reference number. CodeList Summary (Total Codes: 504, Included: 3)	M	AN	1/3	Must use
		Code Name				
		ON Order number (purchase) <i>Description:</i> Reference number assigned by the buyer to an order.				
		<i>Reseller purchase order number</i>				
		VN Order number (vendor) <i>Description:</i> Reference number assigned by supplier to a buyer's purchase order.				
		<i>Ingram Micro sales order number</i>				
		ADE Account number <i>Description:</i> Identification number of an account.				
		<i>Ingram Micro account number</i>				
RFF010-020	1154	Reference number <i>Description:</i> Identification number the nature and function of which can be qualified by an entry in data element 1153 Reference qualifier.	C	AN	1/35	Used

Example:

RFF+ON:4501248101'
RFF+VN:440195716'
RFF+ADE:44465054000'

Segment Group 2

Pos: 0200	Repeat: 99
Conditional	
Group: 2	Elements: N/A

User Option (Usage): Used

Segment Group Summary:

<u>Pos</u>	<u>Tag</u>	<u>Segment Name</u>	<u>Status</u>	<u>Rep</u>	<u>Usage</u>
0210	NAD	Name and address	M	1	Must use
0240		Segment Group 3	C	9999	Used
0300		Segment Group 5	C	5	Used

NAD

Name and address

Pos: 0210	Max: 1
Mandatory	
Group: 2	Elements: 7

User Option (Usage): Must use

Function: To specify the name/address and their related function, either by CO82 only and/or unstructured by CO58 or structured by CO80 thru 3207.

Element Summary:

<u>Ref</u>	<u>Tag</u>	<u>Element Name</u>	<u>Status</u>	<u>Type</u>	<u>Min/Max</u>	<u>Usage</u>
NAD010	3035	Party qualifier	M	AN	1/3	Must use

Description: Code giving specific meaning to a party.

CodeList Summary (Total Codes: 325, Included: 3)

<u>Code</u>	<u>Name</u>	<u>Description</u>
BY	Buyer	Description: <i>Party to which merchandise is sold.</i>
CN	Consignee	Description: <i>Party to which goods are consigned.</i>
SU	Supplier	Description: <i>Party which manufactures or otherwise has possession of goods, and consigns or makes them available in trade.</i>

NAD020	C082	Party identification details	C	Comp		Used
Description: Identification of a transaction party by code.						

NAD020-010	3039	Party id. identification	M	AN	1/35	Must use
Description: Code identifying a party involved in a transaction.						

NAD020-030	3055	Code list responsible agency, coded	C	AN	1/3	Used
Description: Code identifying the agency responsible for a code list.						

CodeList Summary (Total Codes: 195, Included: 3)

<u>Code</u>	<u>Name</u>	<u>Description</u>
9	EAN (International Article Numbering association)	Description: <i>Self explanatory.</i>
91	Assigned by seller or seller's agent	
92	Assigned by buyer or buyer's agent	

NAD040	C080	Party name	C	Comp		Used
Description: Identification of a transaction party by name, one to five lines. Party name may be formatted.						

NAD040-010	3036	Party name	M	AN	1/35	Must use
Description: Name of a party involved in a transaction.						

NAD040-020	3036	Party name	C	AN	1/35	Used
Description: Name of a party involved in a transaction.						

NAD050	C059	Street	C	Comp		Used
Description: Street address and/or PO Box number in a structured address: one to four lines.						

NAD050-010	3042	Street and number/P.O. box Description: Street and number in plain language, or Post Office Box No.	M	AN	1/35	Must use
NAD050-020	3042	Street and number/p.o. box Description: Street and number in plain language, or Post Office Box No.	C	AN	1/35	Used
NAD050-030	3042	Street and number/p.o. box Description: Street and number in plain language, or Post Office Box No.	C	AN	1/35	Used
NAD060	3164	City name Description: Name of a city (a town, a village) for addressing purposes.	C	AN	1/35	Used
NAD080	3251	Postcode identification Description: Code defining postal zones or addresses.	C	AN	1/9	Used
NAD090	3207	Country, coded Description: Identification of the name of a country or other geographical entity as specified in ISO 3166.	C	AN	1/3	Used

Example:

```
NAD+BY+PARTYID::91++NAME+STREET+CITY++POST CODE+DE'
NAD+CN+++NAME+STREET+CITY++POST CODE+DE'
NAD+SU+++INGRAM MICRO DISTRIBUTION GMBH+HEISENBERGBOGEN 3+ DORNACH B.
MUENCHEN++85609+DE'
```

Segment Group 3

Pos: 0240	Repeat: 9999
Conditional	
Group: 3	Elements: N/A

User Option (Usage): Used

Segment Group Summary:

<u>Pos</u>	<u>Tag</u>	<u>Segment Name</u>	<u>Status</u>	<u>Rep</u>	<u>Usage</u>
0250	RFF	REFERENCE	M	1	Must use

RFF REFERENCE

Pos: 0250	Max: 1
Mandatory	
Group: 3	Elements: 1

User Option (Usage): Must use
Function: To specify a reference.

Element Summary:

<u>Ref</u>	<u>Tag</u>	<u>Element Name</u>	<u>Status</u>	<u>Type</u>	<u>Min/Max</u>	<u>Usage</u>
RFF010	C506	Reference Description: VAT reference number	M	Comp		Must use
RFF010-010	1153	Reference qualifier Description: Code giving specific meaning to a reference segment or a reference number.	M	AN	1/3	Must use
CodeList Summary (Total Codes: 504, Included: 2)						
		Code		Name		
		FC		Fiscal number Description: Tax payer's number. Number assigned to individual persons as well as to corporates by a public institution; this number is different from the VAT registration number.		
		VA		<i>Provided for Germany only</i> VAT registration number Description: Unique number assigned by the relevant tax authority to identify a party for use in relation to Value Added Tax (VAT).		
RFF010-020	1154	Reference number	C	AN	1/35	Used

Example:

RFF+VA:DE129422178'
 RFF+FC:143/814/31894'

Segment Group 5

Pos: 0300	Repeat: 5
Conditional	
Group: 5	Elements: N/A

User Option (Usage): Used

Segment Group Summary:

<u>Pos</u>	<u>Tag</u>	<u>Segment Name</u>	<u>Status</u>	<u>Rep</u>	<u>Usage</u>
0310	CTA	Contact information	M	1	Must use
0320	COM	Communication contact	C	5	Used

CTA Contact information

Pos: 0310	Max: 1
Mandatory	
Group: 5	Elements: 2

User Option (Usage): Must use

Function: To identify a person or a department to whom communication should be directed.

Element Summary:

<u>Ref</u>	<u>Tag</u>	<u>Element Name</u>	<u>Status</u>	<u>Type</u>	<u>Min/Max</u>	<u>Usage</u>				
CTA010	3139	Contact function, coded Description: Code specifying the function of a contact (e.g. department or person). CodeList Summary (Total Codes: 85, Included: 1) <table border="1"> <thead> <tr> <th><u>Code</u></th> <th><u>Name</u></th> </tr> </thead> <tbody> <tr> <td>IC</td> <td>Information contact</td> </tr> </tbody> </table> Description: <i>Department/person to contact for questions regarding transactions.</i>	<u>Code</u>	<u>Name</u>	IC	Information contact	C	an	1/3	Used
<u>Code</u>	<u>Name</u>									
IC	Information contact									
CTA020	C056	Department or employee details Description: Code and/or name of a department or employee. Code preferred.	C	Comp		Used				
CTA020-020	3412	Department or employee Description: The department or person within an organizational entity.	C	an	1/35	Used				

Example:

CTA+IC+:IECC ESOLUTIONS SUPPORT'

COM Communication contact

Pos: 0320	Max: 5
Conditional	
Group: 5	Elements: 1

User Option (Usage): Used

Function: To identify a communication number of a department or a person to whom communication should be directed.

Element Summary:

<u>Ref</u>	<u>Tag</u>	<u>Element Name</u>	<u>Status</u>	<u>Type</u>	<u>Min/Max</u>	<u>Usage</u>
COM010	C076	Communication contact Description: Communication number of a department or employee in a specified channel.	M	Comp		Must use
COM010-010	3148	Communication number Description: The communication number.	M	an	1/512	Must use
COM010-020	3155	Communication channel qualifier Description: Code identifying the type of communication channel being used.	M	an	1/3	Must use

CodeList Summary (Total Codes: 27, Included: 1)

<u>Code</u>	<u>Name</u>
EM	Electronic mail Description: <i>Creating/sending/receiving of unstructured free text messages or documents using computer network, a mini-computer or an attached modem and regular telephone line or other electronic transmission media.</i>

Example:

COM+ESOLUTIONS.SUPPORT@INGRAMMICRO.COM:EM'

Segment Group 7

Pos: 0370	Repeat: 5
Conditional	
Group: 7	Elements: N/A

User Option (Usage): Used

Segment Group Summary:

<u>Pos</u>	<u>Tag</u>	<u>Segment Name</u>	<u>Status</u>	<u>Rep</u>	<u>Usage</u>
0380	CUX	Currencies	M	1	Must use

CUX

Currencies

Pos: 0380	Max: 1
Mandatory	
Group: 7	Elements: 3

User Option (Usage): Must use

Function: To specify currencies used in the transaction and relevant details for the rate of exchange.

Element Summary:

<u>Ref</u>	<u>Tag</u>	<u>Element Name</u>	<u>Status</u>	<u>Type</u>	<u>Min/Max</u>	<u>Usage</u>				
CUX010	C504	Currency details Description: The usage to which a currency relates.	C	Comp		Used				
CUX010-010	6347	Currency details qualifier Description: Specification of the usage to which the currency relates. CodeList Summary (Total Codes: 7, Included: 1) <table border="1"> <thead> <tr> <th><u>Code</u></th> <th><u>Name</u></th> </tr> </thead> <tbody> <tr> <td>2</td> <td>Reference currency Description: <i>The currency applicable to amounts stated. It may have to be converted.</i></td> </tr> </tbody> </table>	<u>Code</u>	<u>Name</u>	2	Reference currency Description: <i>The currency applicable to amounts stated. It may have to be converted.</i>	M	AN	1/3	Must use
<u>Code</u>	<u>Name</u>									
2	Reference currency Description: <i>The currency applicable to amounts stated. It may have to be converted.</i>									
CUX010-020	6345	Currency, coded Description: Identification of the name or symbol of the monetary unit involved in the transaction.	C	AN	1/3	Used				
CUX010-030	6343	Currency qualifier Description: Code giving specific meaning to data element 6345 Currency. CodeList Summary (Total Codes: 17, Included: 1) <table border="1"> <thead> <tr> <th><u>Code</u></th> <th><u>Name</u></th> </tr> </thead> <tbody> <tr> <td>4</td> <td>Invoicing currency Description: <i>The name or symbol of the monetary unit used for calculation in an invoice.</i></td> </tr> </tbody> </table>	<u>Code</u>	<u>Name</u>	4	Invoicing currency Description: <i>The name or symbol of the monetary unit used for calculation in an invoice.</i>	C	an	1/3	Used
<u>Code</u>	<u>Name</u>									
4	Invoicing currency Description: <i>The name or symbol of the monetary unit used for calculation in an invoice.</i>									
CUX020	C504	Currency details Description: The usage to which a currency relates.	C	Comp		Used				
CUX020-010	6347	Currency details qualifier Description: Specification of the usage to which the currency relates. CodeList Summary (Total Codes: 7, Included: 1) <table border="1"> <thead> <tr> <th><u>Code</u></th> <th><u>Name</u></th> </tr> </thead> <tbody> <tr> <td>3</td> <td>Target currency Description: <i>The currency which should be used to the target destination of the transaction.</i></td> </tr> </tbody> </table>	<u>Code</u>	<u>Name</u>	3	Target currency Description: <i>The currency which should be used to the target destination of the transaction.</i>	M	an	1/3	Must use
<u>Code</u>	<u>Name</u>									
3	Target currency Description: <i>The currency which should be used to the target destination of the transaction.</i>									
CUX020-020	6345	Currency, coded Description: Identification of the name or symbol of the monetary unit involved in the transaction.	C	an	1/3	Used				
CUX020-030	6343	Currency qualifier Description: Code giving specific meaning to data element 6345 Currency.	C	an	1/3	Used				

CodeList Summary (Total Codes: 17, Included: 1)

<u>Code</u>	<u>Name</u>
13	Recipient local currency Description: <i>The name or symbol of the local monetary unit at recipient's location.</i>

CUX030	5402	Rate of exchange	C	n	1/12	Used
Description: The rate at which one specified currency is expressed in another specified currency.						

Example:

CUX+2:EUR'

CUX+2:GBP:4+3:EUR:13+1.154390'

Segment Group 8

Pos: 0400	Repeat: 10
Conditional	
Group: 8	Elements: N/A

User Option (Usage): Used

Segment Group Summary:

<u>Pos</u>	<u>Tag</u>	<u>Segment Name</u>	<u>Status</u>	<u>Rep</u>	<u>Usage</u>
0410	PAT	Payment terms basis	M	1	Must use
0420	DTM	Payment Due Date	C	5	Used

PAT Payment terms basis

Pos: 0410	Max: 1
Mandatory	
Group: 8	Elements: 3

User Option (Usage): Must use

Element Summary:

<u>Ref</u>	<u>Tag</u>	<u>Element Name</u>	<u>Status</u>	<u>Type</u>	<u>Min/Max</u>	<u>Usage</u>				
PAT010	4279	Payment terms type qualifier <i>Description:</i> Identification of the type of payment terms. CodeList Summary (Total Codes: 35, Included: 1) <table border="1"> <tr> <th><u>Code</u></th> <th><u>Name</u></th> </tr> <tr> <td>3</td> <td>Fixed date</td> </tr> </table> <i>Description:</i> Self explanatory.	<u>Code</u>	<u>Name</u>	3	Fixed date	M	AN	1/3	Must use
<u>Code</u>	<u>Name</u>									
3	Fixed date									
PAT020	C110	Payment terms <i>Description:</i> Terms of payment code from a specified source.	C	Comp		Used				
PAT020-010	4277	Terms of payment identification <i>Description:</i> Identification of the terms of payment between the parties to a transaction (generic term). CodeList Summary (Total Codes: 6, Included: 1) <table border="1"> <tr> <th><u>Code</u></th> <th><u>Name</u></th> </tr> <tr> <td>6</td> <td>No drafts</td> </tr> </table> <i>Description:</i> No drafts required.	<u>Code</u>	<u>Name</u>	6	No drafts	M	an	1/17	Must use
<u>Code</u>	<u>Name</u>									
6	No drafts									
PAT020-040	4276	Terms of payment <i>Description:</i> Conditions of payment between the parties to a transaction (generic term).	C	an	1/35	Used				
PAT030	C112	Terms/time information <i>Description:</i> Time details in payment terms.	C	Comp		Used				
PAT030-010	2475	Payment time reference, coded <i>Description:</i> Code relating payment terms to the date of a specific event. CodeList Summary (Total Codes: 62, Included: 1) <table border="1"> <tr> <th><u>Code</u></th> <th><u>Name</u></th> </tr> <tr> <td>66</td> <td>Specified date</td> </tr> </table> <i>Description:</i> Date specified in the following DTM segment.	<u>Code</u>	<u>Name</u>	66	Specified date	M	AN	1/3	Must use
<u>Code</u>	<u>Name</u>									
66	Specified date									
PAT030-020	2009	Time relation, coded <i>Description:</i> Code relating payment terms to a time before, on or after the reference date. CodeList Summary (Total Codes: 12, Included: 1) <table border="1"> <tr> <th><u>Code</u></th> <th><u>Name</u></th> </tr> <tr> <td>1</td> <td>Reference date</td> </tr> </table> <i>Description:</i> Payment terms related to reference date.	<u>Code</u>	<u>Name</u>	1	Reference date	C	AN	1/3	Used
<u>Code</u>	<u>Name</u>									
1	Reference date									

Example:

PAT+3+6:::PAYMENT TERMS+66:1'

DTM Payment Due Date

Pos: 0420	Max: 5
Conditional	
Group: 8	Elements: 1

User Option (Usage): Used

Function: To specify date payment is due.

Element Summary:

<u>Ref</u>	<u>Tag</u>	<u>Element Name</u>	<u>Status</u>	<u>Type</u>	<u>Min/Max</u>	<u>Usage</u>
DTM010	C507	Date Description: Date relevant to the specified date.	M	Comp		Must use
DTM010-010	2005	Date qualifier Description: Code giving specific meaning to a date. CodeList Summary (Total Codes: 364, Included: 1)	M	AN	1/3	Must use
		Code Name 13 Terms net due date Description: <i>Date by which payment must be made.</i>				
DTM010-020	2380	Payment due date Description: CCYYMMDD	C	AN	1/35	Used
DTM010-030	2379	Date format qualifier Description: Specification of the representation of a date. CodeList Summary (Total Codes: 70, Included: 1)	C	AN	1/3	Used
		Code Name 102 CCYYMMDD Description: <i>Calendar date</i> <i>CC = Century</i> <i>YY = Year</i> <i>MM = Month</i> <i>DD = Day.</i>				

Example:

DTM+13:20070808:102'

Segment Group 25

Pos: 1030	Repeat: 9999999
Conditional	
Group: 25	Elements: N/A

User Option (Usage): Used

Segment Group Summary:

<u>Pos</u>	<u>Tag</u>	<u>Segment Name</u>	<u>Status</u>	<u>Rep</u>	<u>Usage</u>
1040	LIN	Line item	M	1	Must use
1050	PIA	Additional product id	C	25	Used
1060	IMD	Item description	C	10	Used
1080	QTY	Quantity	C	5	Used
1120	GIN	Goods identity number	C	1000	Used
1180		Segment Group 26	C	10	Used
1260		Segment Group 28	C	25	Used
1320		Segment Group 29	C	10	Used
1480		Segment Group 33	C	99	Used
1640		Segment Group 38	C	30	Used

LIN

Line item

Pos: 1040	Max: 1
Mandatory	
Group: 25	Elements: 2

User Option (Usage): Must use

Function: Identifies a line item and its configuration.

Element Summary:

<u>Ref</u>	<u>Tag</u>	<u>Element Name</u>	<u>Status</u>	<u>Type</u>	<u>Min/Max</u>	<u>Usage</u>				
LIN010	1082	Line item number Description: Serial number designating each separate item within a series of articles.	C	AN	1/6	Used				
LIN030	C212	Item number identification. Description: Goods identification for a specific commodity.	C	Comp		Used				
LIN030-010	7140	Ingram Micro part code Description: A code allocated to a commodity by Ingram Micro.	C	AN	1/35	Used				
LIN030-020	7143	Item number type, coded Description: Identification of the type of item number. CodeList Summary (Total Codes: 86, Included: 1) <table style="width: 100%; border-collapse: collapse;"><thead><tr><th style="text-align: left;"><u>Code</u></th><th style="text-align: left;"><u>Name</u></th></tr></thead><tbody><tr><td>VP</td><td>Vendors part number</td></tr></tbody></table> Description: <i>Indicates that the reference number was allocated by Ingram Micro</i>	<u>Code</u>	<u>Name</u>	VP	Vendors part number	C	AN	1/3	Used
<u>Code</u>	<u>Name</u>									
VP	Vendors part number									
LIN030-040	3055	Code list responsible agency, coded Description: Code identifying the agency responsible for a code list. CodeList Summary (Total Codes: 195, Included: 1) <table style="width: 100%; border-collapse: collapse;"><thead><tr><th style="text-align: left;"><u>Code</u></th><th style="text-align: left;"><u>Name</u></th></tr></thead><tbody><tr><td>91</td><td>Assigned by seller or seller's agent</td></tr></tbody></table>	<u>Code</u>	<u>Name</u>	91	Assigned by seller or seller's agent	C	AN	1/3	Used
<u>Code</u>	<u>Name</u>									
91	Assigned by seller or seller's agent									

Example:

LIN+1++943Y626:VP::91'

PIA

Additional product id

Pos: 1050	Max: 25
Conditional	
Group: 25	Elements: 2

User Option (Usage): Used

Function: To specify additional or substitutional item identification codes.

Element Summary:

<u>Ref</u>	<u>Tag</u>	<u>Element Name</u>	<u>Status</u>	<u>Type</u>	<u>Min/Max</u>	<u>Usage</u>								
PIA010	4347	Product id. function qualifier Description: Indication of the function of the product code. CodeList Summary (Total Codes: 9, Included: 1) <table border="1"> <thead> <tr> <th><u>Code</u></th> <th><u>Name</u></th> </tr> </thead> <tbody> <tr> <td>1</td> <td>Alternative product codes</td> </tr> </tbody> </table>	<u>Code</u>	<u>Name</u>	1	Alternative product codes	M	AN	1/3	Must use				
<u>Code</u>	<u>Name</u>													
1	Alternative product codes													
PIA020	C212	Item number identification Description: Goods identification for a specified source, multiple C212 composites may be used.	M	Comp		Must use								
PIA020-010	7140	Item number Description: A number allocated to a group or item.	C	AN	1/35	Used								
PIA020-020	7143	Item number type, coded Description: Identification of the type of item number. CodeList Summary (Total Codes: 86, Included: 3) <table border="1"> <thead> <tr> <th><u>Code</u></th> <th><u>Name</u></th> </tr> </thead> <tbody> <tr> <td>BP</td> <td>Buyer's part number Description: <i>Reference number assigned by the buyer to identify an article.</i></td> </tr> <tr> <td>EN</td> <td>International Article Numbering Association (EAN) Description: <i>Number assigned to a manufacturer's product according to the International Article Numbering Association.</i></td> </tr> <tr> <td>MF</td> <td>Manufacturer's (producer's) article number Description: <i>The number given to an article by its manufacturer.</i></td> </tr> </tbody> </table>	<u>Code</u>	<u>Name</u>	BP	Buyer's part number Description: <i>Reference number assigned by the buyer to identify an article.</i>	EN	International Article Numbering Association (EAN) Description: <i>Number assigned to a manufacturer's product according to the International Article Numbering Association.</i>	MF	Manufacturer's (producer's) article number Description: <i>The number given to an article by its manufacturer.</i>	C	AN	1/3	Used
<u>Code</u>	<u>Name</u>													
BP	Buyer's part number Description: <i>Reference number assigned by the buyer to identify an article.</i>													
EN	International Article Numbering Association (EAN) Description: <i>Number assigned to a manufacturer's product according to the International Article Numbering Association.</i>													
MF	Manufacturer's (producer's) article number Description: <i>The number given to an article by its manufacturer.</i>													
PIA020-040	3055	Code list responsible agency, coded Description: Code identifying the agency responsible for a code list. CodeList Summary (Total Codes: 195, Included: 3) <table border="1"> <thead> <tr> <th><u>Code</u></th> <th><u>Name</u></th> </tr> </thead> <tbody> <tr> <td>9</td> <td>EAN (International Article Numbering association)</td> </tr> <tr> <td>90</td> <td>Assigned by manufacturer</td> </tr> <tr> <td>92</td> <td>Assigned by buyer or buyer's agent</td> </tr> </tbody> </table>	<u>Code</u>	<u>Name</u>	9	EAN (International Article Numbering association)	90	Assigned by manufacturer	92	Assigned by buyer or buyer's agent	C	AN	1/3	Used
<u>Code</u>	<u>Name</u>													
9	EAN (International Article Numbering association)													
90	Assigned by manufacturer													
92	Assigned by buyer or buyer's agent													

Example:

PIA+1+103887:BP::92'
PIA+1+C7986A:MF::90'
PIA+1+0725184396694:EN::9'

IMD

Item description

Pos: 1060	Max: 10
Conditional	
Group: 25	Elements: 2

User Option (Usage): Used

Function: To describe an item in either an industry or free format.

Element Summary:

<u>Ref</u>	<u>Tag</u>	<u>Element Name</u>	<u>Status</u>	<u>Type</u>	<u>Min/Max</u>	<u>Usage</u>				
IMD010	7077	Item description type, coded Description: Code indicating the format of a description. CodeList Summary (Total Codes: 8, Included: 1) <table border="1"> <thead> <tr> <th><u>Code</u></th> <th><u>Name</u></th> </tr> </thead> <tbody> <tr> <td>F</td> <td>Free-form</td> </tr> </tbody> </table> Description: <i>Self explanatory.</i>	<u>Code</u>	<u>Name</u>	F	Free-form	C	AN	1/3	Used
<u>Code</u>	<u>Name</u>									
F	Free-form									
IMD030	C273	Item description	C	Comp		Used				
IMD030-040	7008	Item description Description: Plain language description of articles or products.	C	AN	1/35	Used				
IMD030-050	7008	Item description Description: Continuation of plain language description of articles or products.	C	AN	1/35	Used				

Example:

IMD+F+:::8.4GB OPTICAL DISC ACCS:2024BPS'

QTY

Quantity

Pos: 1080	Max: 5
Conditional	
Group: 25	Elements: 1

User Option (Usage): Used

Element Summary:

<u>Ref</u>	<u>Tag</u>	<u>Element Name</u>	<u>Status</u>	<u>Type</u>	<u>Min/Max</u>	<u>Usage</u>				
QTY010	C186	Quantity details Description: Quantity information in a transaction, qualified when relevant.	M	Comp		Must use				
QTY010-010	6063	Quantity qualifier Description: Code giving specific meaning to a quantity. CodeList Summary (Total Codes: 199, Included: 1) <table border="1"> <thead> <tr> <th><u>Code</u></th> <th><u>Name</u></th> </tr> </thead> <tbody> <tr> <td>47</td> <td>Invoiced quantity Description: <i>The quantity as per invoice.</i></td> </tr> </tbody> </table>	<u>Code</u>	<u>Name</u>	47	Invoiced quantity Description: <i>The quantity as per invoice.</i>	M	AN	1/3	Must use
<u>Code</u>	<u>Name</u>									
47	Invoiced quantity Description: <i>The quantity as per invoice.</i>									
QTY010-020	6060	Quantity Description: Numeric value of a quantity.	M	N	1/15	Must use				

Example:

QTY+47:2'

User Note :

Credit notes are shown as negative figures.

GIN

Goods identity number

Pos: 1120	Max: 1000
Conditional	
Group: 25	Elements: 2

User Option (Usage): Used

Function: To give specific identification numbers, either as single numbers or ranges.

Element Summary:

<u>Ref</u>	<u>Tag</u>	<u>Element Name</u>	<u>Status</u>	<u>Type</u>	<u>Min/Max</u>	<u>Usage</u>				
GIN010	7405	Identity number qualifier Description: Code specifying the type/source of identity number. CodeList Summary (Total Codes: 55, Included: 1) <table border="1"> <thead> <tr> <th><u>Code</u></th> <th><u>Name</u></th> </tr> </thead> <tbody> <tr> <td>BN</td> <td>Serial number</td> </tr> </tbody> </table> Description: <i>Identification number of an item which distinguishes this specific item from otherwise identical items.</i>	<u>Code</u>	<u>Name</u>	BN	Serial number	M	AN	1/3	Must use
<u>Code</u>	<u>Name</u>									
BN	Serial number									
GIN020	C208	Identity number range Description: Goods item identification numbers, start and end of consecutively numbered range.	M	Comp		Must use				
GIN020-010	7402	Identity number Description: The number given to an object for its unique identification.	M	AN	1/35	Must use				

Example:

GIN+BN+S010000000T'
GIN+BN+S020000000T'

Segment Group 26

Pos: 1180	Repeat: 10
Conditional	
Group: 26	Elements: N/A

User Option (Usage): Used

Segment Group Summary:

<u>Pos</u>	<u>Tag</u>	<u>Segment Name</u>	<u>Status</u>	<u>Rep</u>	<u>Usage</u>
1190	MOA	Monetary amount	M	1	Must use

MOA Monetary amount

Pos: 1190	Max: 1
Mandatory	
Group: 26	Elements: 1

User Option (Usage): Must use

Function: To specify a monetary amount.

Element Summary:

<u>Ref</u>	<u>Tag</u>	<u>Element Name</u>	<u>Status</u>	<u>Type</u>	<u>Min/Max</u>	<u>Usage</u>				
MOA010	C516	Monetary amount Description: Amount of goods or services stated as a monetary amount in a specified currency.	M	Comp		Must use				
MOA010-010	5025	Monetary amount type qualifier Description: Indication of type of amount. CodeList Summary (Total Codes: 360, Included: 1) <table border="1"> <thead> <tr> <th><u>Code</u></th> <th><u>Name</u></th> </tr> </thead> <tbody> <tr> <td>203</td> <td>Line item amount</td> </tr> </tbody> </table> Description: <i>Goods item total minus allowances plus charges for line item.</i>	<u>Code</u>	<u>Name</u>	203	Line item amount	M	AN	1/3	Must use
<u>Code</u>	<u>Name</u>									
203	Line item amount									
MOA010-020	5004	Monetary amount Description: Number of monetary units.	C	N	1/18	Used				

Example:

MOA+203:131.28'

User Note :

Credit notes are shown as negative figures.

Segment Group 28

Pos: 1260	Repeat: 25
Conditional	
Group: 28	Elements: N/A

User Option (Usage): Used

Segment Group Summary:

<u>Pos</u>	<u>Tag</u>	<u>Segment Name</u>	<u>Status</u>	<u>Rep</u>	<u>Usage</u>
1270	PRI	Price details	M	1	Must use

PRI

Price details

Pos: 1270	Max: 1
Mandatory	
Group: 28	Elements: 1

User Option (Usage): Must use

Function: To specify price information.

Element Summary:

<u>Ref</u>	<u>Tag</u>	<u>Element Name</u>	<u>Status</u>	<u>Type</u>	<u>Min/Max</u>	<u>Usage</u>				
PRI010	C509	Price information Description: Identification of price type, price and related details.	C	Comp		Used				
PRI010-010	5125	Price qualifier Description: Identification of a type of price. CodeList Summary (Total Codes: 10, Included: 1) <table border="1"> <thead> <tr> <th><u>Code</u></th> <th><u>Name</u></th> </tr> </thead> <tbody> <tr> <td>CAL</td> <td>Calculation price Description: <i>The price stated is the price for the calculation of the line item amount.</i></td> </tr> </tbody> </table>	<u>Code</u>	<u>Name</u>	CAL	Calculation price Description: <i>The price stated is the price for the calculation of the line item amount.</i>	M	AN	1/3	Must use
<u>Code</u>	<u>Name</u>									
CAL	Calculation price Description: <i>The price stated is the price for the calculation of the line item amount.</i>									
PRI010-020	5118	Price Description: The monetary value associated with a purchase or sale of an article, product or service.	C	N	1/15	Used				
PRI010-030	5375	Price type, coded Description: Code identifying the type of price of an item. CodeList Summary (Total Codes: 27, Included: 1) <table border="1"> <thead> <tr> <th><u>Code</u></th> <th><u>Name</u></th> </tr> </thead> <tbody> <tr> <td>TU</td> <td>Traded unit Description: <i>The price is referring to the traded unit.</i></td> </tr> </tbody> </table>	<u>Code</u>	<u>Name</u>	TU	Traded unit Description: <i>The price is referring to the traded unit.</i>	C	AN	1/3	Used
<u>Code</u>	<u>Name</u>									
TU	Traded unit Description: <i>The price is referring to the traded unit.</i>									

Example:

PRI+CAL:65.64:TU'

Segment Group 29

Pos: 1320	Repeat: 10
Conditional	
Group: 29	Elements: N/A

User Option (Usage): Used

Segment Group Summary:

<u>Pos</u>	<u>Tag</u>	<u>Segment Name</u>	<u>Status</u>	<u>Rep</u>	<u>Usage</u>
1330	RFF	Customer Purchase Order code	M	1	Must use

RFF

Customer Purchase Order code

Pos: 1330	Max: 1
Mandatory	
Group: 29	Elements: 1

User Option (Usage): Must use

Element Summary:

<u>Ref</u>	<u>Tag</u>	<u>Element Name</u>	<u>Status</u>	<u>Type</u>	<u>Min/Max</u>	<u>Usage</u>				
RFF010	C506	Reference Description: Identification of a reference.	M	Comp		Must use				
RFF010-010	1153	Reference qualifier Description: Code giving specific meaning to a reference segment or a reference number. CodeList Summary (Total Codes: 504, Included: 1) <table border="1"> <thead> <tr> <th><u>Code</u></th> <th><u>Name</u></th> </tr> </thead> <tbody> <tr> <td>ON</td> <td>Order number (purchase)</td> </tr> </tbody> </table> Description: <i>Reference number assigned by the buyer to an order.</i>	<u>Code</u>	<u>Name</u>	ON	Order number (purchase)	M	AN	1/3	Must use
<u>Code</u>	<u>Name</u>									
ON	Order number (purchase)									
RFF010-020	1154	Reference number Description: Identification number the nature and function of which can be qualified by an entry in data element 1153 Reference qualifier.	C	AN	1/35	Used				
RFF010-030	1156	Line number Description: Number of the line in the document/message referenced in 1154 Reference number.	C	AN	1/6	Used				

Example:

RFF+ON:4501277182:20'

Segment Group 33

Pos: 1480	Repeat: 99
Conditional	
Group: 33	Elements: N/A

User Option (Usage): Used

Segment Group Summary:

<u>Pos</u>	<u>Tag</u>	<u>Segment Name</u>	<u>Status</u>	<u>Rep</u>	<u>Usage</u>
1490	TAX	Duty/tax/fee details	M	1	Must use
1500	MOA	Monetary amount	C	1	Used

TAX

Duty/tax/fee details

Pos: 1490	Max: 1
Mandatory	
Group: 33	Elements: 3

User Option (Usage): Must use

Function: To specify relevant duty/tax/fee information.

Element Summary:

<u>Ref</u>	<u>Tag</u>	<u>Element Name</u>	<u>Status</u>	<u>Type</u>	<u>Min/Max</u>	<u>Usage</u>				
TAX010	5283	Duty/tax/fee function qualifier Description: Code identifying the function of an duty, tax or fee information. CodeList Summary (Total Codes: 8, Included: 1) <table border="1"> <thead> <tr> <th><u>Code</u></th> <th><u>Name</u></th> </tr> </thead> <tbody> <tr> <td>7</td> <td>Tax</td> </tr> </tbody> </table> Description: <i>Contribution levied by an authority.</i>	<u>Code</u>	<u>Name</u>	7	Tax	M	an	1/3	Must use
<u>Code</u>	<u>Name</u>									
7	Tax									
TAX020	C241	Duty/tax/fee type Description: Code and/or name identifying duty, tax or fee.	C	Comp		Used				
TAX020-010	5153	Duty/tax/fee type, coded Description: Identification of the type of duty or tax or fee applicable to commodities or of tax applicable to services. CodeList Summary (Total Codes: 45, Included: 1) <table border="1"> <thead> <tr> <th><u>Code</u></th> <th><u>Name</u></th> </tr> </thead> <tbody> <tr> <td>VAT</td> <td>Value added tax</td> </tr> </tbody> </table> Description: <i>A tax on domestic or imported goods applied to the value added at each stage in the production/distribution cycle.</i>	<u>Code</u>	<u>Name</u>	VAT	Value added tax	C	an	1/3	Used
<u>Code</u>	<u>Name</u>									
VAT	Value added tax									
TAX050	C243	Duty/tax/fee detail Description: Rate of duty/tax/fee applicable to commodities or of tax applicable to services.	C	Comp		Used				
TAX050-040	5278	Duty/tax/fee rate Description: Rate of duty or tax or fee applicable to commodities or of tax applicable to services.	C	an	1/17	Used				

Example:

TAX+7+VAT+++:::20'

MOA Monetary amount

Pos: 1500	Max: 1
Conditional	
Group: 33	Elements: 1

User Option (Usage): Used

Function: To specify a monetary amount.

Element Summary:

<u>Ref</u>	<u>Tag</u>	<u>Element Name</u>	<u>Status</u>	<u>Type</u>	<u>Min/Max</u>	<u>Usage</u>
MOA010	C516	Monetary amount Description: Amount of goods or services stated as a monetary amount in a specified currency.	M	Comp		Must use
MOA010-010	5025	Monetary amount type qualifier Description: Indication of type of amount.	M	an	1/3	Must use
CodeList Summary (Total Codes: 360, Included: 2)						
		<u>Code</u>		<u>Name</u>		
		124		Tax amount Description: Tax imposed by government or other official authority related to the weight/volume charge or valuation charge.		
		125		Taxable amount Description: Self explanatory.		
MOA010-020	5004	Monetary amount Description: Number of monetary units.	C	n	1/18	Used

Example:

MOA+125:33.2'

MOA+124:6.64'

Segment Group 38

Pos: 1640	Repeat: 30
Conditional	
Group: 38	Elements: N/A

User Option (Usage): Used

Segment Group Summary:

<u>Pos</u>	<u>Tag</u>	<u>Segment Name</u>	<u>Status</u>	<u>Rep</u>	<u>Usage</u>
1650	ALC	Allowance or charge	M	1	Must use
1750		Segment Group 41	C	2	Used
1830		Segment Group 43	C	5	Used

ALC

Allowance or charge

Pos: 1650	Max: 1
Mandatory	
Group: 38	Elements: 3

User Option (Usage): Must use

Function: To identify allowance or charge details.

Element Summary:

<u>Ref</u>	<u>Tag</u>	<u>Element Name</u>	<u>Status</u>	<u>Type</u>	<u>Min/Max</u>	<u>Usage</u>						
ALC010	5463	Allowance or charge qualifier Description: Specification of an allowance or charge for the service specified. CodeList Summary (Total Codes: 24, Included: 1) <table border="1"> <thead> <tr> <th><u>Code</u></th> <th><u>Name</u></th> </tr> </thead> <tbody> <tr> <td>C</td> <td>Charge</td> </tr> </tbody> </table> Description: <i>Self explanatory.</i>	<u>Code</u>	<u>Name</u>	C	Charge	M	an	1/3	Must use		
<u>Code</u>	<u>Name</u>											
C	Charge											
ALC030	4471	Settlement, coded Description: Indication of how allowances or charges are to be settled. CodeList Summary (Total Codes: 25, Included: 1) <table border="1"> <thead> <tr> <th><u>Code</u></th> <th><u>Name</u></th> </tr> </thead> <tbody> <tr> <td>1</td> <td>Bill back</td> </tr> </tbody> </table> Description: <i>Refers to a charge or allowance for the buyer and the buyer will bill back the seller.</i>	<u>Code</u>	<u>Name</u>	1	Bill back	C	an	1/3	Used		
<u>Code</u>	<u>Name</u>											
1	Bill back											
ALC050	C214	Special services identification Description: Identification of a special service by a code from a specified source or by description.	C	Comp		Used						
ALC050-010	7161	Special services, coded Description: Code identifying a special service. CodeList Summary (Total Codes: 262, Included: 2) <table border="1"> <thead> <tr> <th><u>Code</u></th> <th><u>Name</u></th> </tr> </thead> <tbody> <tr> <td>AAK</td> <td>Energy surcharge</td> </tr> <tr> <td>ACQ</td> <td>Royalty surcharge</td> </tr> </tbody> </table> Description: <i>Additional charge on an item's price for royalty.</i>	<u>Code</u>	<u>Name</u>	AAK	Energy surcharge	ACQ	Royalty surcharge	C	an	1/3	Used
<u>Code</u>	<u>Name</u>											
AAK	Energy surcharge											
ACQ	Royalty surcharge											
ALC050-030	3055	Code list responsible agency, coded Description: Code identifying the agency responsible for a code list.	C	an	1/3	Used						
ALC050-040	7160	Special service Description: Description of a special service.	C	an	1/35	Used						

Example:

ALC+C++1++AAK:::CONTRIBUTION ENVIRONNEMENTA'

Segment Group 41

Pos: 1750	Repeat: 2
Conditional	
Group: 41	Elements: N/A

User Option (Usage): Used

Segment Group Summary:

<u>Pos</u>	<u>Tag</u>	<u>Segment Name</u>	<u>Status</u>	<u>Rep</u>	<u>Usage</u>
1760	MOA	Monetary amount	M	1	Must use

MOA Monetary amount

Pos: 1760	Max: 1
Mandatory	
Group: 41	Elements: 1

User Option (Usage): Must use

Function: To specify a monetary amount.

Element Summary:

<u>Ref</u>	<u>Tag</u>	<u>Element Name</u>	<u>Status</u>	<u>Type</u>	<u>Min/Max</u>	<u>Usage</u>				
MOA010	C516	Monetary amount Description: Amount of goods or services stated as a monetary amount in a specified currency.	M	Comp		Must use				
MOA010-010	5025	Monetary amount type qualifier Description: Indication of type of amount. CodeList Summary (Total Codes: 360, Included: 1)	M	an	1/3	Must use				
		<table border="1"> <thead> <tr> <th><u>Code</u></th> <th><u>Name</u></th> </tr> </thead> <tbody> <tr> <td>23</td> <td>Charge amount Description: <i>Self explanatory.</i></td> </tr> </tbody> </table>	<u>Code</u>	<u>Name</u>	23	Charge amount Description: <i>Self explanatory.</i>				
<u>Code</u>	<u>Name</u>									
23	Charge amount Description: <i>Self explanatory.</i>									
MOA010-020	5004	Monetary amount Description: Number of monetary units.	C	n	1/18	Used				

Example:

MOA+23:.0336'

Segment Group 43

Pos: 1830	Repeat: 5
Conditional	
Group: 43	Elements: N/A

User Option (Usage): Used

Segment Group Summary:

<u>Pos</u>	<u>Tag</u>	<u>Segment Name</u>	<u>Status</u>	<u>Rep</u>	<u>Usage</u>
1840	TAX	Duty/tax/fee details	M	1	Must use

TAX

Duty/tax/fee details

Pos: 1840	Max: 1
Mandatory	
Group: 43	Elements: 3

User Option (Usage): Must use

Function: To specify relevant duty/tax/fee information.

Element Summary:

<u>Ref</u>	<u>Tag</u>	<u>Element Name</u>	<u>Status</u>	<u>Type</u>	<u>Min/Max</u>	<u>Usage</u>				
TAX010	5283	Duty/tax/fee function qualifier Description: Code identifying the function of an duty, tax or fee information. CodeList Summary (Total Codes: 8, Included: 1) <table border="1"> <thead> <tr> <th><u>Code</u></th> <th><u>Name</u></th> </tr> </thead> <tbody> <tr> <td>7</td> <td>Tax</td> </tr> </tbody> </table> Description: <i>Contribution levied by an authority.</i>	<u>Code</u>	<u>Name</u>	7	Tax	M	an	1/3	Must use
<u>Code</u>	<u>Name</u>									
7	Tax									
TAX020	C241	Duty/tax/fee type Description: Code and/or name identifying duty, tax or fee.	C	Comp		Used				
TAX020-010	5153	Duty/tax/fee type, coded Description: Identification of the type of duty or tax or fee applicable to commodities or of tax applicable to services. CodeList Summary (Total Codes: 45, Included: 1) <table border="1"> <thead> <tr> <th><u>Code</u></th> <th><u>Name</u></th> </tr> </thead> <tbody> <tr> <td>VAT</td> <td>Value added tax</td> </tr> </tbody> </table> Description: <i>A tax on domestic or imported goods applied to the value added at each stage in the production/distribution cycle.</i>	<u>Code</u>	<u>Name</u>	VAT	Value added tax	C	an	1/3	Used
<u>Code</u>	<u>Name</u>									
VAT	Value added tax									
TAX050	C243	Duty/tax/fee detail Description: Rate of duty/tax/fee applicable to commodities or of tax applicable to services.	C	Comp		Used				
TAX050-040	5278	Duty/tax/fee rate Description: Rate of duty or tax or fee applicable to commodities or of tax applicable to services.	C	an	1/17	Used				

Example:

TAX+7+VAT+++:::20'

UNS

Section control

Pos: 2090	Max: 1
Mandatory	
Group: N/A	Elements: 1

User Option (Usage): Must use

Function: To separate header, detail, and summary sections of a message.

Element Summary:

<u>Ref</u>	<u>Tag</u>	<u>Element Name</u>	<u>Status</u>	<u>Type</u>	<u>Min/Max</u>	<u>Usage</u>
UNS010	0081	Section identification	M	A	1/1	Must use

Description: A character identifying the next section in a message.

CodeList Summary (Total Codes: 2, Included: 1)

<u>Code</u>	<u>Name</u>
S	Detail/summary section separation

Description: *To qualify the segment UNS, when separating the detail from the summary section of a message.*

Example:

UNS+S'

CNT

Control total

Pos: 2100	Max: 10
Conditional	
Group: N/A	Elements: 1

User Option (Usage): Used
Function: To provide control total.

Element Summary:

<u>Ref</u>	<u>Tag</u>	<u>Element Name</u>	<u>Status</u>	<u>Type</u>	<u>Min/Max</u>	<u>Usage</u>				
CNT010	C270	Control Description: Control total for checking integrity of a message or part of a message.	M	Comp		Must use				
CNT010-010	6069	Control qualifier Description: Determines the source data elements in the message which forms the basis for 6066 Control value. CodeList Summary (Total Codes: 38, Included: 1) <table border="1"> <thead> <tr> <th><u>Code</u></th> <th><u>Name</u></th> </tr> </thead> <tbody> <tr> <td>4</td> <td>Number of invoice lines</td> </tr> </tbody> </table> Description: <i>Number of lines on an invoice.</i>	<u>Code</u>	<u>Name</u>	4	Number of invoice lines	M	AN	1/3	Must use
<u>Code</u>	<u>Name</u>									
4	Number of invoice lines									
CNT010-020	6066	Control value Description: Value obtained from summing the values specified by the Control Qualifier throughout the message (Hash total).	M	N	1/18	Must use				

Example:

CNT+4:1'

Segment Group 49

Pos: 2110	Repeat: 100
Mandatory	
Group: 49	Elements: N/A

User Option (Usage): Must use

Segment Group Summary:

<u>Pos</u>	<u>Tag</u>	<u>Segment Name</u>	<u>Status</u>	<u>Rep</u>	<u>Usage</u>
2120	MOA	Monetary amount	M	1	Must use

MOA Monetary amount

Pos: 2120	Max: 1
Mandatory	
Group: 49	Elements: 1

User Option (Usage): Must use
Function: To specify a monetary amount.

Element Summary:

<u>Ref</u>	<u>Tag</u>	<u>Element Name</u>	<u>Status</u>	<u>Type</u>	<u>Min/Max</u>	<u>Usage</u>
MOA010	C516	Monetary amount Description: Amount of goods or services stated as a monetary amount in a specified currency.	M	Comp		Must use
MOA010-010	5025	Monetary amount type qualifier Description: Indication of type of amount.	M	AN	1/3	Must use
CodeList Summary (Total Codes: 360, Included: 6)						
		<u>Code</u>		<u>Name</u>		
		9		Amount due/amount payable Description: <i>Amount to be paid.</i>		
		79		Total line items amount Description: <i>The sum of all the line item amounts.</i>		
		124		Tax amount Description: <i>Tax imposed by government or other official authority related to the weight/volume charge or valuation charge.</i>		
		125		Taxable amount		
		131		Total charges/allowances Description: <i>The amount specified is the total of all charges/allowances.</i>		
MOA010-020	5004	Monetary amount Description: Number of monetary units.	C	N	1/18	Used
MOA010-030	6345	Currency, coded Description: Identification of the name or symbol of the monetary unit involved in the transaction.	C	an	1/3	Used
MOA010-040	6343	Currency qualifier Description: Code giving specific meaning to data element 6345 Currency.	C	an	1/3	Used
CodeList Summary (Total Codes: 17, Included: 2)						
		<u>Code</u>		<u>Name</u>		
		4		Invoicing currency Description: <i>The name or symbol of the monetary unit used for calculation in an invoice.</i>		
		13		Recipient local currency Description: <i>The name or symbol of the local monetary unit at recipient's location.</i>		

Example:

MOA+9:156.22'
 MOA+79:131.28'
 MOA+125:131.28'
 MOA+124:24.94'

Target currency:

MOA+9:128.17'

MOA+79:104.20'

MOA+125:104.20:GBP:4'

MOA+125:120.28:EUR:13'

MOA+124:23.97:GBP:4'

MOA+124:27.67:EUR:13'

User Note :

Credit notes are shown as negative figures.

Segment Group 51

Pos: 2160	Repeat: 10
Conditional	
Group: 51	Elements: N/A

User Option (Usage): Used

Segment Group Summary:

<u>Pos</u>	<u>Tag</u>	<u>Segment Name</u>	<u>Status</u>	<u>Rep</u>	<u>Usage</u>
2170	TAX	Duty/tax/fee details	M	1	Must use
2180	MOA	Monetary amount	C	2	Used

TAX

Duty/tax/fee details

Pos: 2170	Max: 1
Mandatory	
Group: 51	Elements: 3

User Option (Usage): Must use

Function: To specify relevant duty/tax/fee information.

Element Summary:

<u>Ref</u>	<u>Tag</u>	<u>Element Name</u>	<u>Status</u>	<u>Type</u>	<u>Min/Max</u>	<u>Usage</u>				
TAX010	5283	Duty/tax/fee function qualifier Description: '7'	M	AN	1/3	Must use				
TAX020	C241	Duty/tax/fee type Description: Code and/or name identifying duty, tax or fee.	C	Comp		Used				
TAX020-010	5153	Duty/tax/fee type, coded Description: Identification of the type of duty or tax or fee applicable to commodities or of tax applicable to services. CodeList Summary (Total Codes: 45, Included: 1) <table border="1"> <thead> <tr> <th><u>Code</u></th> <th><u>Name</u></th> </tr> </thead> <tbody> <tr> <td>VAT</td> <td>Value added tax Description: A tax on domestic or imported goods applied to the value added at each stage in the production/distribution cycle.</td> </tr> </tbody> </table>	<u>Code</u>	<u>Name</u>	VAT	Value added tax Description: A tax on domestic or imported goods applied to the value added at each stage in the production/distribution cycle.	C	AN	1/3	Used
<u>Code</u>	<u>Name</u>									
VAT	Value added tax Description: A tax on domestic or imported goods applied to the value added at each stage in the production/distribution cycle.									
TAX050	C243	Duty/tax/fee detail Description: Rate of duty/tax/fee applicable to commodities or of tax applicable to services.	C	Comp		Used				
TAX050-040	5278	Duty/tax/fee rate Description: Rate of duty or tax or fee applicable to commodities or of tax applicable to services.	C	an	1/17	Used				

Example:

TAX+7+VAT+++:::19'

MOA Monetary amount

Pos: 2180	Max: 2
Conditional	
Group: 51	Elements: 1

User Option (Usage): Used
Function: To specify a monetary amount.

Element Summary:

<u>Ref</u>	<u>Tag</u>	<u>Element Name</u>	<u>Status</u>	<u>Type</u>	<u>Min/Max</u>	<u>Usage</u>
MOA010	C516	Monetary amount <i>Description:</i> Amount of goods or services stated as a monetary amount in a specified currency.	M	Comp		Must use
MOA010-010	5025	Monetary amount type qualifier <i>Description:</i> Indication of type of amount. CodeList Summary (Total Codes: 360, Included: 2)	M	AN	1/3	Must use
		Code Name				
		124 Tax amount <i>Description:</i> Tax imposed by government or other official authority related to the weight/volume charge or valuation charge.				
		125 Taxable amount				
MOA010-020	5004	Monetary amount <i>Description:</i> Number of monetary units.	C	N	1/18	Used
MOA010-030	6345	Currency, coded <i>Description:</i> Identification of the name or symbol of the monetary unit involved in the transaction.	C	an	1/3	Used
MOA010-040	6343	Currency qualifier <i>Description:</i> Code giving specific meaning to data element 6345 Currency. CodeList Summary (Total Codes: 17, Included: 2)	C	an	1/3	Used
		Code Name				
		4 Invoicing currency <i>Description:</i> The name or symbol of the monetary unit used for calculation in an invoice.				
		13 Recipient local currency <i>Description:</i> The name or symbol of the local monetary unit at recipient's location.				

Example:

MOA+125:131.28'
 MOA+124:24.94'

Target currency

MOA+125:104.20:GBP:4'
 MOA+125:120.28:EUR:13'
 MOA+124:23.97:GBP:4'
 MOA+124:27.67:EUR:13'

User Note :

Credit notes are shown as negative figures.

Segment Group 52

Pos: 2190	Repeat: 15
Conditional	
Group: 52	Elements: N/A

User Option (Usage): Used

Segment Group Summary:

<u>Pos</u>	<u>Tag</u>	<u>Segment Name</u>	<u>Status</u>	<u>Rep</u>	<u>Usage</u>
2200	ALC	Allowance or charge	M	1	Must use
2220	MOA	Monetary amount	C	2	Used

ALC Allowance or charge

Pos: 2200	Max: 1
Mandatory	
Group: 52	Elements: 3

User Option (Usage): Must use

Function: To identify allowance or charge details.

Element Summary:

<u>Ref</u>	<u>Tag</u>	<u>Element Name</u>	<u>Status</u>	<u>Type</u>	<u>Min/Max</u>	<u>Usage</u>						
ALC010	5463	Allowance or charge qualifier Description: Specification of an allowance or charge for the service specified. CodeList Summary (Total Codes: 24, Included: 1) <table border="1"> <thead> <tr> <th><u>Code</u></th> <th><u>Name</u></th> </tr> </thead> <tbody> <tr> <td>C</td> <td>Charge</td> </tr> </tbody> </table> Description: <i>Self explanatory.</i>	<u>Code</u>	<u>Name</u>	C	Charge	M	an	1/3	Must use		
<u>Code</u>	<u>Name</u>											
C	Charge											
ALC020	C552	Allowance/charge information Description: Identification of allowance/charge information by number and/or code.	C	Comp		Used						
ALC050	C214	Special services identification Description: Identification of a special service by a code from a specified source or by description.	C	Comp		Used						
ALC050-010	7161	Special services, coded Description: Code identifying a special service. CodeList Summary (Total Codes: 262, Included: 2) <table border="1"> <thead> <tr> <th><u>Code</u></th> <th><u>Name</u></th> </tr> </thead> <tbody> <tr> <td>FC</td> <td>Freight charge</td> </tr> <tr> <td>TX</td> <td>Tax</td> </tr> </tbody> </table> Description: <i>Amount to be paid for moving goods, by whatever means, from one place to another, inclusive discounts, allowances, rebates, adjustment factors and additional cost relating to freight costs (UN/ECE Recommendation no 23).</i> Description: <i>Contribution levied by an authority.</i>	<u>Code</u>	<u>Name</u>	FC	Freight charge	TX	Tax	C	an	1/3	Used
<u>Code</u>	<u>Name</u>											
FC	Freight charge											
TX	Tax											
ALC050-040	7160	Special service Description: Description of a special service.	C	an	1/35	Used						

Example:

```
ALC+C++++TX:::REMUNERATION COPIE PRIVEE'
ALC+C++++FC:::FREIGHT'
```

MOA Monetary amount

Pos: 2220	Max: 2
Conditional	
Group: 52	Elements: 1

User Option (Usage): Used

Function: To specify a monetary amount.

Element Summary:

<u>Ref</u>	<u>Tag</u>	<u>Element Name</u>	<u>Status</u>	<u>Type</u>	<u>Min/Max</u>	<u>Usage</u>				
MOA010	C516	Monetary amount Description: Amount of goods or services stated as a monetary amount in a specified currency.	M	Comp		Must use				
MOA010-010	5025	Monetary amount type qualifier Description: Indication of type of amount. CodeList Summary (Total Codes: 360, Included: 1) <table border="1"> <thead> <tr> <th><u>Code</u></th> <th><u>Name</u></th> </tr> </thead> <tbody> <tr> <td>8</td> <td>Allowance or charge amount Description: [5422] Total amount of allowance or charge.</td> </tr> </tbody> </table>	<u>Code</u>	<u>Name</u>	8	Allowance or charge amount Description: [5422] Total amount of allowance or charge.	M	an	1/3	Must use
<u>Code</u>	<u>Name</u>									
8	Allowance or charge amount Description: [5422] Total amount of allowance or charge.									
MOA010-020	5004	Monetary amount Description: Number of monetary units.	C	n	1/18	Used				
MOA010-040	6343	Currency qualifier Description: Code giving specific meaning to data element 6345 Currency. CodeList Summary (Total Codes: 17, Included: 1) <table border="1"> <thead> <tr> <th><u>Code</u></th> <th><u>Name</u></th> </tr> </thead> <tbody> <tr> <td>4</td> <td>Invoicing currency Description: The name or symbol of the monetary unit used for calculation in an invoice.</td> </tr> </tbody> </table>	<u>Code</u>	<u>Name</u>	4	Invoicing currency Description: The name or symbol of the monetary unit used for calculation in an invoice.	C	an	1/3	Used
<u>Code</u>	<u>Name</u>									
4	Invoicing currency Description: The name or symbol of the monetary unit used for calculation in an invoice.									

Example:

MOA+8:14'

UNT

Message trailer

Pos: 2240	Max: 1
Mandatory	
Group: N/A	Elements: 2

User Option (Usage): Must use

Function: To end and check the completeness of a message.

Element Summary:

<u>Ref</u>	<u>Tag</u>	<u>Element Name</u>	<u>Status</u>	<u>Type</u>	<u>Min/Max</u>	<u>Usage</u>
UNT010	0074	Number of segments in a message Description: Control count of number of segments in a message.	M	N	1/6	Must use
UNT020	0062	Message reference number Description: Unique message reference assigned by the sender.	M	AN	1/14	Must use

Example:

UNT+39+00000000000001'

UNZ INTERCHANGE TRAILER

Pos:	Max: 1
Mandatory	
Group: N/A	Elements: 2

User Option (Usage): Must use

Function: To end and check the completeness of an interchange.

Element Summary:

<u>Ref</u>	<u>Tag</u>	<u>Element Name</u>	<u>Status</u>	<u>Type</u>	<u>Min/Max</u>	<u>Usage</u>
UNZ010	0036	Interchange control count Description: Count either of the number of messages or, if used, of the number of functional groups in an interchange.	M	n	1/6	Must use
UNZ020	0020	Interchange control reference Description: Unique reference assigned by the sender to an interchange.	M	an	1/14	Must use

Example:

UNZ+522+00000000000024'

Sample Messages

UNA:+.? '
 UNB+UNOC:2+004919486DE:01+RESELLER:14+070808:0955+00000000000024++INVOIC++++1'
 UNH+00000000000001+INVOIC:D:97A:UN'
 BGM+380+440405253:9'
 DTM+3:20070730:102'
 DTM+137:20070809:102'
 RFF+ON:4501248101'
 RFF+VN:440195716'
 RFF+ADE:44465054000'
 NAD+BY+PARTYID::91++NAME+STREET+CITY++POST CODE+DE'
 NAD+CN+++NAME+STREET+CITY++POST CODE+DE'
 NAD+SU+++INGRAM MICRO DISTRIBUTION GMBH+HEISENBERGBOGEN 3+ DORNACH B. MUENCHEN++85609+DE'
 RFF+VA:DE129422178'
 RFF+FC:143/814/31894'
 CTA+IC+:IECC ESOLUTIONS SUPPORT'
 COM+ESOLUTIONS.SUPPORT@INGRAMMICRO.COM:EM'
 CUX+2:EUR'
 PAT+3+6:::PAYMENT TERMS+66:1'
 DTM+13:20070808:102'
 LIN+1++943Y626:VP:::91'
 PIA+1+103887:BP:::92'
 PIA+1+C7986A:MF:::90'
 PIA+1+0725184396694:EN:::9'
 IMD+F+++:::8.4GB OPTICAL DISC ACCS:2024BPS'
 QTY+47:2'
 GIN+BN+S010000000T'
 GIN+BN+S020000000T'
 MOA+203:131.28'
 PRI+CAL:65.64:TU'
 RFF+ON:4501277182:20'
 TAX+7+VAT+++:::20'
 MOA+125:131.28'
 MOA+124:26.26'
 ALC+C++1++AAK:::CONTRIBUTION ENVIRONNEMENTA'
 MOA+23:5'
 TAX+7+VAT+++:::20'
 UNS+S'
 CNT+4:1'
 MOA+9:174.34'
 MOA+79:136.28'
 MOA+125:145.28'
 MOA+124:29.06'
 TAX+7+VAT+++:::19'
 MOA+125:145.28'
 MOA+124:24.94'
 ALC+C++++TX:::REMUNERATION COPIE PRIVEE'
 MOA+8:5'
 ALC+C++++FC:::FREIGHT'
 MOA+8:9'
 UNT+48+00000000000001'
 UNZ+1+00000000000024'

Target Currency

UNA:+.?'
 UNB+UNOC:2+004919486DE:01+RESELLER:14+070808:0955+0000000000024++INVOIC++++1'
 UNH+00000000000001+INVOIC:D:97A:UN'
 BGM+380+440405253:9'
 DTM+3:20070730:102'
 DTM+137:20070809:102'
 RFF+ON:4501248101'
 RFF+VN:440195716'
 RFF+ADE:44465054000'
 NAD+BY+PARTYID::91++NAME+STREET+CITY++POST CODE+DE'
 NAD+CN+++NAME+STREET+CITY++POST CODE+DE'
 NAD+SU+++INGRAM MICRO DISTRIBUTION GMBH+HEISENBERGBOGEN 3+ DORNACH B. MUENCHEN++85609+DE'
 RFF+VA:DE129422178'
 RFF+FC:143/814/31894'
 CTA+IC+:IECC ESOLUTIONS SUPPORT'
 COM+ESOLUTIONS.SUPPORT@INGRAMMICRO.COM:EM'
 CUX+2:GBP:4+3:EUR:13+1.154390'
 PAT+3+6:::PAYMENT TERMS+66:1'
 DTM+13:20070808:102'
 LIN+1++943Y626:VP::91'
 PIA+1+103887:BP::92'
 PIA+1+C7986A:MF::90'
 PIA+1+0725184396694:EN::9'
 IMD+F+++::8.4GB OPTICAL DISC ACCS:2024BPS'
 QTY+47:2'
 GIN+BN+S010000000T'
 GIN+BN+S020000000T'
 MOA+203:131.28'
 PRI+CAL:65.64:TU'
 RFF+ON:4501277182:20'
 TAX+7+VAT++++:::20'
 MOA+125:131.28'
 MOA+124:26.26'
 ALC+C++1++AAK:::CONTRIBUTION ENVIRONNEMENTA'
 MOA+23:5'
 TAX+7+VAT++++:::20'
 UNS+S'
 CNT+4:1'
 MOA+9:174.34'
 MOA+79:136.28'
 MOA+125:145.28:GBP:4'
 MOA+125:167.71:EUR:13'
 MOA+124:29.06:GBP:4'
 MOA+124:33.55:EUR:13'
 TAX+7+VAT++++:::19'
 MOA+125:145.28:GBP:4'
 MOA+125:167.71:EUR:13'
 MOA+124:29.06:GBP:4'
 MOA+124:33.55:EUR:13'
 ALC+C++++TX:::REMUNERATION COPIE PRIVEE'
 MOA+8:5'
 ALC+C++++FC:::FREIGHT'
 MOA+8:9'
 EDIFACTD97A

UNT+54+00000000000001'
UNZ+1+00000000000024'